

## ANALYSIS OF GATE 2017\* Civil Engineering

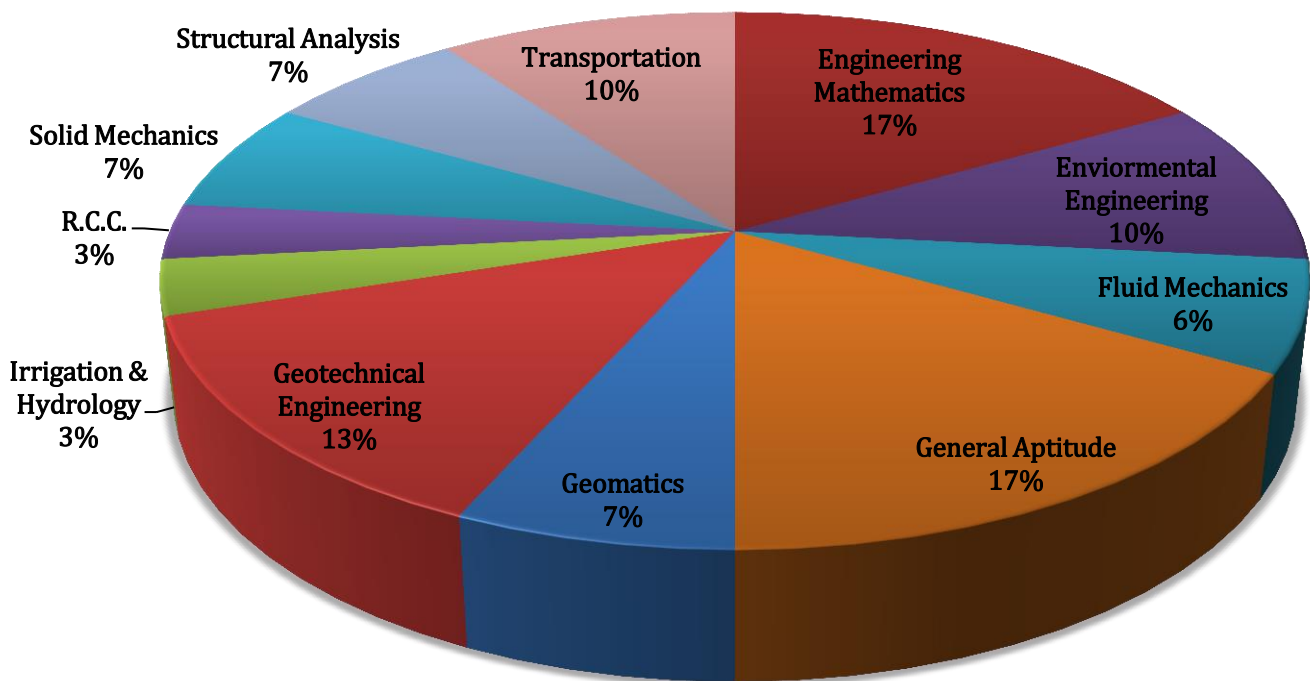

**CE ANALYSIS-2017\_12-Feb\_Morning**

SUBJECT	No. of Ques.	Topics Asked in Paper(Memory Based)	Level of Ques.	Total Marks
Engineering Mathematics	1 Marks:5 2 Marks:4	Linear Algebra, Probability and Distribution, Calculus, Numerical Methods, Differential Equations	Easy	13
Fluid Mechanics	1 Marks:2 2 Marks:3	Flow through pipes, Open Channel flow	Medium	8
Environmental Engineering	1 Marks:3 2 Marks:4	Waste Water Treatment, Air Pollution, Noise pollutions, Detention Tank	Tough	11
Structural Analysis	1 Marks:2 2 Marks:3	Influence Line Diagram and Rolling Loads, Trusses and Arches, cables, Displacement Method	Tough	8
R.C.C.	1 Marks:1 2 Marks:2	Design of Pre-Stressed Concrete Beams, Columns , Limit State analysis	Medium	5
Geotechnical Engineering	1 Marks:4 2 Marks:4	Shear Strength, Consolidation, Stress Distribution, Infine Slope, Index Properties and Soil Classification	Medium	12
Transportation Engineering	1 Marks:3 2 Marks:3	Theory of Traffic Flow and Highway Capacity, Airport, Traffic Engg	Tough	9
CMM	1 Marks:0 2 Marks:1	Pert Analysis	Tough	2
Irrigation & Hydrology	1 Marks:1 2 Marks:2	Irrigation, Hydrology	Easy	5
Engineering Mechanics	1 Marks:0 2 Marks:1	Mechanics	Medium	2
Solid Mechanics	1 Marks:2 2 Marks:1	Simple Stress and Stain, Strain Energy Method	Medium	4
Steel structure	1 Marks:0 2 Marks:1	Bolted Connection	Tough	2
Geomatics	1 Marks:2 2 Marks:1	Measurements	Easy	4
General Aptitude	1 Marks:5 2 Marks:5	Probability, Numerical ability, Passage, Grammar	Medium	15
<b>Total</b>	<b>65</b>			<b>100</b>
<b>Faculty Feedback</b>	Majority of the question were concept based. ENV, FM, SA and GT weightage was comparatively high. GA was medium as compared to the last year.			

**GATE 2017 Examination**  
**Civil Engineering**

Test Date: 12/02/2017  
Test Time: 9:00 AM 12:00 PM  
Subject Name: Civil Engineering

**Section I General Aptitude**

1. Consider the following sentences.  
All benches are beds. No bed is a bulb. Some bulbs are lamps.  
Which of the following can be inferred?  
i. Some beds are lamps  
ii. Some lamps are beds  
(A) Only i (C) Both i and ii  
(B) Only ii (D) Neither i nor ii

**[Ans. D]**

From the given statements, the following Venn diagrams are possible

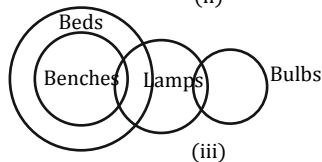
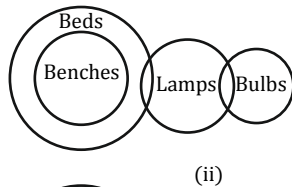
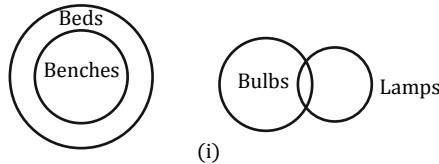

Given conclusions (i) and (ii) are not possible from the above diagrams, so option (D) is correct.

2. The following sequence of numbers is arranged in increasing order: 1, x, x, x, y, y, 9, 16, 18 given that the mean and median are equal, and are also equal to twice the mode, the value of y is  
(A) 5 (C) 7  
(B) 6 (D) 8

**[Ans. D]**

Given increasing order of number sequence is 1, x, x, x, y, y, 9, 16, 18

Total number of numbers = 9

Mean = Median = 2 Mode (given)

$$\begin{aligned} \text{Mean} &= \frac{\text{Sum of numbers}}{\text{Total number of numbers}} = \frac{1 + x + x + x + y + y + 9 + 16 + 18}{9} \\ &= \frac{1 + 3x + 2y + 16 + 18 + 9}{9} \\ &= \frac{3x + 2y + 44}{9} \dots \dots \textcircled{1} \end{aligned}$$

Median  $\Rightarrow$  As number of terms are odd (i.e) 9 so, median will be middle of the sequence = y

Mode = Number showing maximum frequency of repetition = x (three times)

From the given condition

$$y = 2x \dots \dots \textcircled{2}$$

By solving equation  $\textcircled{1}$  and  $\textcircled{2}$ , we get  $x = 4, y = 8$

$\therefore$  The value of y is 8

3. If the radius of a right circular cone is increased by 50% its volume increases by
- |          |            |
|----------|------------|
| (A) 75%  | (C) 125%   |
| (B) 100% | (D) 237.5% |

**[Ans. C]**

Volume of a right circular cone

$$V = \frac{1}{3}\pi R^2 H$$

R = radius of a cone

H = height of the cone

$$V \propto R^2$$

$$V_1 = R^2$$

$$V_2 = (1.5)^2 R^2 \text{ with increasing}$$

$$V_2 = 2.25 R^2 = 2.25V_1$$

$$\begin{aligned} \therefore \text{Volume increases} &= \frac{V_2 - V_1}{V_1} \times 100 \\ &= \frac{2.25V_1 - V_1}{V_1} \times 100 \\ &= \frac{V_1(1.25)}{V_1} \times 100 = 1.25 \times 100 = 125\% \end{aligned}$$

4. \_\_\_\_\_ with someone else's email account is now a very serious offence
- |               |                |
|---------------|----------------|
| (A) Involving | (C) Tampering  |
| (B) Assisting | (D) Incubating |

**[Ans. C]**

Tampering means to carry on under hand or improper negotiations/ to interfere so as to weaken/change for the worse.

5. The bacteria in milk are destroyed when it \_\_\_\_\_ heated to 80 degree Celsius.
- |              |         |
|--------------|---------|
| (A) would be | (C) is  |
| (B) will be  | (D) was |

**[Ans. C]**

Habitual action/automatic results.

6. Students applying for hostel rooms are allotted rooms in order of seniority. Students already staying in a room will move if they get a room in their preferred list. Preferences of lower ranked applicants are ignored during allocation.

Given the data below, which room will Ajit stay in?

Names	Student seniority	Current Room	Room preference list
Amar	1	P	R.S.Q
Akbar	2	None	R.S
Anthony	3	Q	P
Ajit	4	S	Q.P.R

- (A) P (C) R  
(B) Q (D) S

**[Ans. B]**

From given table, According to their preferences Room 'R' is preferred by Amar, Akbar and Ajit but Amar is senior so, Room 'R' is for Amar and from the preference list Akbar is compulsory stay in Room 'S' only, Anthony is preferred only one room 'P' only so, P is for Anthony.

∴ The room for Ajit is 'Q'

Persons	Rooms to be allotted
Amar	R
Akabr	S
Anthony	P
Ajit	Q

7. Two machines M<sub>1</sub> and M<sub>2</sub> are able to execute any of four jobs P,Q,R and S. The machines can perform one job on one object at a time. Jobs P,Q,R and S take 30 minutes, 20 minutes, 60 minutes and 15 minutes each respectively. There are 10 objects each requiring exactly 1 job. Job P is to be performed on 2 objects. Job Q on 3 objects. Job R on 1 object and Job S and 4 objects. What is the minimum time needed to complete all the jobs?
- (A) 2 hours (C) 3 hours  
(B) 2.5 hours (D) 3.5 hours

**[Ans. A]**

If Machine M<sub>1</sub> is able to execute jobs P and Q

If Machine M<sub>2</sub> is able to execute jobs R and S

For Job 'P' time taken 30 minutes with 2 objects =  $2 \times 30 = 60$  min

For Job 'Q' is taken 20 minutes with 3 objects =  $20 \times 3 = 60$  min

∴ Total time taken by Machine (M<sub>1</sub>) for jobs P and Q =  $60 \text{ min} + 60 \text{ min} = 2 \text{ hrs}$

For Job 'R' is taken 60 min with 1 object =  $60 \times 1 = 60$  min

For Job 'S' is taken 15 min with 4 objects =  $4 \times 15 = 60$  min

∴ Total time taken by machine (M<sub>2</sub>) for Jobs R and S =  $60 + 60 = 2 \text{ hrs}$

8. The last digit of  $(2171)^7 + (2172)^9 + (2173)^{11} + (2174)^{13}$  is
- (A) 2 (C) 6  
(B) 4 (D) 8

**[Ans. B]**

Given equation

$$(2171)^7 + (2172)^9 + (2173)^{11} + (2174)^{13}$$

All power values are divide with 4 then the possible remainders are 3, 1, 3 and 1

$$(1)^3 + (2)^1 + (3)^3 + (4)^1$$

$$1 + 2 + 27 + 4 = 34$$

∴ The last digit is '4'

9. The bar graph below shows the output of five carpenters over one month, each of whom made different items of furniture: chairs, tables, and beds.

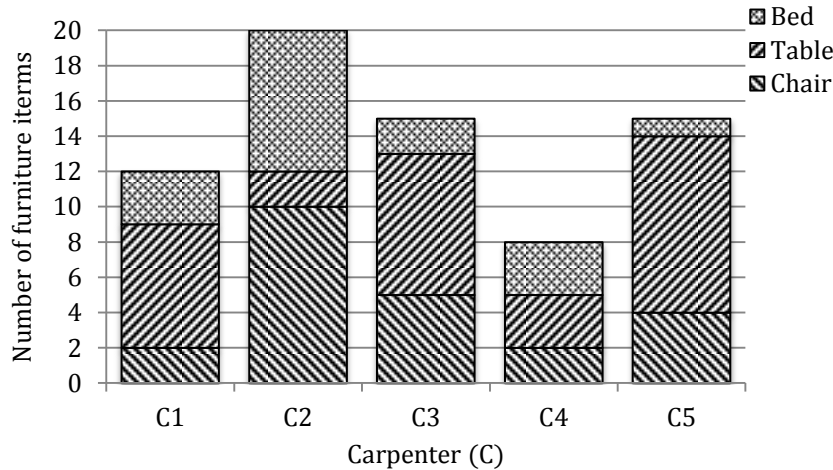

Consider the following statements

- The number of beds made by carpenter C<sub>2</sub> is exactly the same as the number of tables made by carpenter C<sub>3</sub>.
- The total number of chairs made by all carpenters is less than the total number of tables

Which one of the following is true?

- (A) Only i  
(B) Only ii  
(C) Both i and ii  
(D) Neither i nor ii

**[Ans. C]**

From the given bar graph,

- (i) The number of beds made by carpenter C<sub>2</sub> = The number tables made by carpenter C<sub>3</sub>  
8 Nos = 8 Nos

∴ Statement (i) is true

- (ii) The total number of chairs made by all carpenters = C<sub>1</sub> + C<sub>2</sub> + C<sub>3</sub> + C<sub>4</sub> + C<sub>5</sub>  
= 2 + 10 + 5 + 2 + 4 = 23 Nos

$$\begin{aligned} \text{The total numbers of tables made by all carpenters} &= C_1 + C_2 + C_3 + C_4 + C_5 \\ &= 7 + 2 + 8 + 3 + 9 = 29 \text{ Nos} \end{aligned}$$

$$23 \text{ Nos} < 29 \text{ Nos}$$

∴ Statement (ii) is also true

∴ Both the statements (i) and (ii) are true

10. The old concert hall was demolished because of fears that the foundation would be affected by the construction of the new metro line in the area. Modern technology for underground metro construction tried to mitigate the impact of pressurized air pockets created by the excavation of large amounts of soil. But even with these safeguards, it was feared that the soil below the concert hall would not be stable. From this, one can infer that

- (A) The foundation of old buildings create pressurized air pockets underground, which are difficult to handle during metro construction
- (B) Metro construction has to be done carefully considering its impact on the foundations of existing buildings
- (C) Old buildings in an area form an impossible hurdle to metro construction in that area
- (D) Pressurized air can be used to excavate large amounts of soil from underground areas.

[Ans. B]

**Section II Technical**

1. The ordinates of a 2-hour unit hydrograph for a catchment are given as

<b>Time(h)</b>	0	1	2	3	4
<b>Ordinate (m<sup>3</sup>/s)</b>	0	5	12	25	41

The ordinate (in m<sup>3</sup>/s) of a 4-hour unit hydrograph for this catchment at the time of 3 h would be \_\_\_\_\_

[Ans. \*] Range: 15 to 15

Time	2hr UHG Ord.	2hr delayed 2hr UHG ordinate	4hr DRH ordinate	4hr UHG ordinate= 4hr DRH/2
0	0	-		
1	5	-		
2	12	0		
3	25	5	30	15

Ordinate of 4 hr UHG at 3<sup>rd</sup> hr time interval = 15 m<sup>3</sup>/sec

2. A uniformly distributed line load of 500 kN/m is acting on the ground surface. Based on Boussinesq’s theory, the ratio of vertical stress at a depth 2 m to that at 4 m, right below the line of loading, is
- (A) 0.25
  - (B) 0.5
  - (C) 2.0
  - (D) 4.0

[Ans. C]

Extending Boussinesq’s equation for point load, the vertical stress directly below the line load,

$$\sigma_z = \frac{2q'}{\pi z}$$

$$\therefore \sigma_z \propto \frac{1}{z}$$

$$\frac{\sigma_z \text{ at 2m depth}}{\sigma_z \text{ at 4m depth}} = \frac{4}{2} = 2$$

3. According to IS 456- 2000, which one of the following statements about the depth of neutral axis  $x_{u,bal}$  for a balanced reinforced concrete section is correct?
- (A)  $x_{u,bal}$  depends on the grade of concrete only
  - (B)  $x_{u,bal}$  depends on the grade of steel only
  - (C)  $x_{u,bal}$  depends on both the grade of concrete and grade of steel.
  - (D)  $x_{u,bal}$  does not depend on the grade of concrete and grade of steel.

[Ans. B]

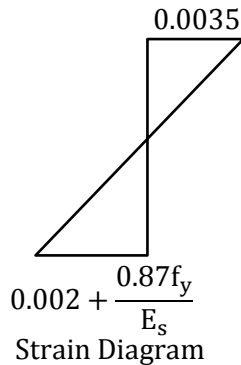

Max depth of N.A,

$$x_{u,bal} = \left[ \frac{0.0035}{0.0055 + \frac{0.87f_y}{E_s}} \right] d$$

Where  $f_y \rightarrow$  yield stress of steel

$E_s \rightarrow$  Modulus of elasticity of steel

$$E_s = 2 \times 10^5 \text{ N/mm}^2$$

From the above formula  $x_{u,max}$  depends on only grade of steel

$$x_{u,bal} = 0.53d \rightarrow \text{Fe} - 250$$

$$x_{u,bal} = 0.48d \rightarrow \text{Fe} - 415$$

$$x_{u,bal} = 0.46d \rightarrow \text{Fe} - 500$$

4. Group I lists the type of gain or loss of strength in soils. Group II lists the property or process responsible for the loss or gain of strength in soils.

Group I	Group -II
P. Regain of strength with time	1. Boiling
Q. Loss of strength due to cyclic loading	2. Liquefaction
R. Loss of strength due to upward seepage	3. Thixotropy
S. Loss of strength due to remolding	4. Sensitivity

The correct match between Group I and Group II is

(A) P-4, Q-1, R-2, S-3

(C) P-3, Q-2, R-1, S-4

(B) P-3, Q-1, R-2, S-4

(D) P-4, Q-2, R-1, S-3

[Ans. C]

5. A runway is being constructed in a new airport as per the International Civil Aviation Organization (ICAO) recommendations. The elevation and the airport reference temperature of this airport are 535 m above the mean sea level and 22.65°C, respectively. Consider the effective gradient of runway as 1%. The length of runway required for a design-aircraft under the standard conditions is 2000 m. Within the framework of applying sequential corrections as per the ICAO recommendations, the length of runway corrected for the temperature is

(A) 2223 m

(C) 2500 m

(B) 2250 m

(D) 2750 m

[Ans. C]

Elevation of airport = 535 m



Airport reference temperature,  
 $ART = 22.65^{\circ}\text{C}$   
 Effective gradient = 1%  
 Standard length of runway = 2000 m

**Correction for elevation:**

300 m – 7%

$$535 \text{ m} \rightarrow ? = \frac{7 \times 535}{300} = 12.48\%$$

Length after elevation correction =  $2000 \times 1.1248 = 2249.6 \text{ m}$

**Temperature correction:**

$ART = 22.65^{\circ}\text{C}$

Standard airport temperature, SAT at msl =  $15^{\circ}\text{C}$

Temperature gradient 1000 m elevation =  $6.5^{\circ}\text{C}$  reduction

$$\text{For } 535 \text{ m elevation reduction of temperature} = \frac{6.5 \times 535}{1000} = 3.48^{\circ}\text{C}$$

$$\therefore \text{SAT at airport site} = 15 - 3.48 = 11.52^{\circ}\text{C}$$

For  $1^{\circ}\text{C}$  difference of ART and SAT = 1% increase in length is recommended by ICAO

For  $(22.65 - 11.52) = 11.13^{\circ}\text{C}$  of difference

Increase in length of runway is 11.13%

$$\begin{aligned} \therefore \text{Final length of runway after temperature correction} &= 2249.6 \times 1.113 \\ &= 2499.98 \text{ m} \approx 2500 \text{ m} \end{aligned}$$

6. A soil sample is subjected to a hydrostatic pressure,  $\sigma$ . The Mohr circle for any point in the soil sample would be
- (A) a circle of radius  $\sigma$  and center at the origin
  - (B) a circle of radius  $\sigma$  and center at a distance  $\sigma$  from the origin
  - (C) a point at a distance  $\sigma$  from the origin
  - (D) a circle of diameter  $\sigma$  and center at the origin

**[Ans. C]**

For hydrostatic pressure ( $\sigma_1 = \sigma_2 = \sigma_3$ ), the Mohr's circle will be a point at a distance  $\sigma$  from the origin.

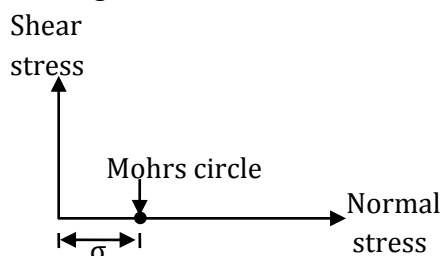

7. The figure shows a two-hinged parabolic arch of span  $L$  subjected to a uniformly distributed load of intensity  $q$  per unit length.

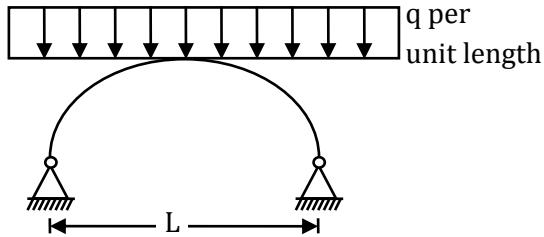

The maximum bending moment in the arch is equal to

- (A)  $\frac{qL^2}{8}$  (C) Zero  
(B)  $\frac{qL^2}{12}$  (D)  $\frac{qL^2}{10}$

[Ans. C]

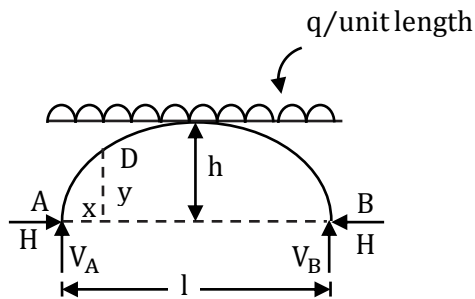

For a 2-hinged parabolic arch

$$V_A = V_B = \frac{ql}{2} \text{ and } H = \frac{ql^2}{8h}$$

$$\text{Taking any point D; } y = \frac{4h}{l^2} x(1-x)$$

$$M_D = V_A x - H \times y - q \frac{x^2}{2} = \frac{ql}{2} x - \frac{ql^2}{8h} \times \frac{4h}{l^2} x(1-x) - \frac{qx^2}{2} = 0$$

8. For a steady incompressible laminar flow between two infinite parallel stationary plates, the shear stress variation is
- (A) linear with zero value at the plates (C) quadratic with zero value at the plates  
(B) linear with zero value at the center (D) quadratic with zero value at the center

[Ans. B]

9. An elastic bar of length  $L$ , uniform cross sectional area  $A$ , coefficient of thermal expansion  $\alpha$ , and Young's modulus  $E$  is fixed at the two ends. The temperature of the bar is increased by  $T$ , resulting in an axial stress  $\sigma$ . Keeping all other parameters unchanged, if the length of the bar is doubled, the axial stress would be

- (A)  $\sigma$  (C)  $0.5 \sigma$   
(B)  $2 \sigma$  (D)  $0.25 \alpha \sigma$

[Ans. A]

Temperature stress,  $\alpha = (\alpha t)E$

Temperature stress is independent of length. If length is doubled the stress due to temperature remains unchanged.

10. The number of parameters in the univariate exponential and Gaussian distributions, respectively, are

(A) 2 and 2 (C) 2 and 1  
(B) 1 and 2 (D) 1 and 1

[Ans. B]

11. The wastewater from a city, containing a high concentration of biodegradable organics, is being steadily discharged into a flowing river at a location S. If the rate of aeration of the river water is lower than the rate of degradation of the organics, then the dissolved oxygen of the river water

(A) is lowest at the location S.  
(B) is lowest at a point upstream of the location S  
(C) remains constant all along the length of the river  
(D) is lowest at a point downstream of the location S.

[Ans. D]

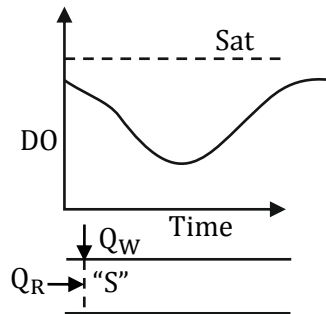

Distance = Velocity  $\times$  Time

DO is lowest point downstream of the location 'S'.

12. The reaction rate involving reactants A and B is given by  $-k[A]^\alpha[B]^\beta$ . Which one of the following statements is valid for the reaction to be a first-order reaction?

(A)  $\alpha = 0$  and  $\beta = 0$  (C)  $\alpha = 1$  and  $\beta = 1$   
(B)  $\alpha = 1$  and  $\beta = 0$  (D)  $\alpha = 1$  and  $\beta = 2$

[Ans. B]

Since it is 1<sup>st</sup> order reaction the sum of the powers must be 1. (i. e  $\alpha + \beta = 1$ )

13. A strip footing is resting on the ground surface of a pure clay bed having an un-drained cohesion  $C_u$ . The ultimate bearing capacity of the footing is equal to

(A)  $2\pi C_u$  (C)  $(\pi + 1)C_u$   
(B)  $\pi C_u$  (D)  $(\pi + 2)C_u$

[Ans. D]

For pure clays, the ultimate bearing capacity of strip footing resting on the ground surface,  
 $q_n = CN_c$

$N_c = 5.7$ , as per Terzaghi

$N_c = 5.14$  as per Meyerhof Hansen, Skempton's-vesic and I.S. code bearing capacity theories.

In the present case  $q_u = 5.14 C$  (or)  $q_u = (\pi + 2)C$

14. A simply supported beam is subjected to a uniformly distributed load. Which one of the following statements is true?
- (A) Maximum or minimum shear force occurs where the curvature is zero
  - (B) Maximum or minimum bending moment occurs where the shear force is zero
  - (C) Maximum or minimum bending moment occurs where the curvature is zero
  - (D) Maximum bending moment and maximum shear force occur at the same section.

[Ans. B]

15.

$\lim_{(x \rightarrow 0)} \left( \frac{\tan x}{x^2 - x} \right)$  is equal to \_\_\_\_\_

[Ans. \*] Range: -1.1 to -0.9

$\lim_{(x \rightarrow 0)} \left( \frac{\tan x}{x^2 - x} \right)$  ( $\frac{0}{0}$  form)

Applying L Hospital rule =  $\lim_{x \rightarrow 0} \left( \frac{\sec^2 x}{2x - 1} \right) = \frac{\sec^2 0}{-1} - 1$

16. A triangular pipe network is shown in the figure.

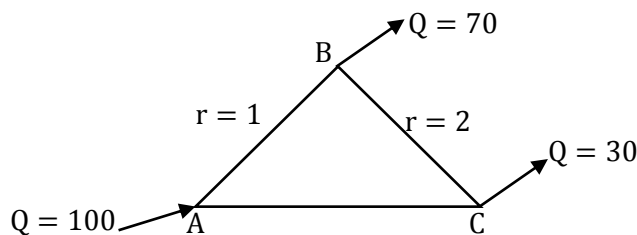

The head loss in each pipe is given by  $h_f = rQ^{1.8}$ , with the variables expressed in a consistent set of units. The value of  $r$  for the pipe AB is 1 and for the pipe BC is 2. If the discharge supplied at the point A (i.e. 100) is equally divided between the pipes AB and AC, the value of  $r$  (up to two decimal places) for the pipe AC should be \_\_\_\_\_

[Ans. \*] Range: 0.60 to 0.63

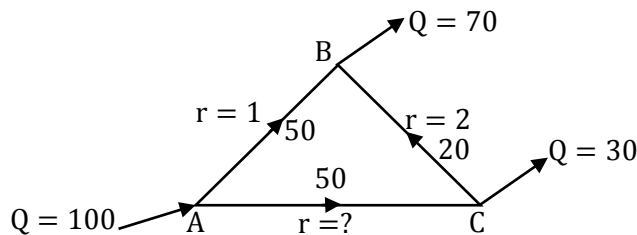

$$h_f = rQ^{1.8}$$

$$\sum h_f = 0$$

$$+1(50)^{1.8} - 2(20)^{1.8} - r(50)^{1.8} = 0$$

$$r = 0.62$$

17. A super-elevation  $e$  is provided on a circular horizontal curve such that a vehicle can be stopped on the curve without sliding. Assuming a design speed  $v$  and maximum coefficient of side friction  $f_{\max}$ , which one of the following criteria should be satisfied?
- (A)  $e \leq f_{\max}$  (C) No limit on  $e$  can be set  
(B)  $e > f_{\max}$  (D)  $e = \frac{1-(f_{\max})^2}{f_{\max}}$

**[Ans. A]**

For a stopped vehicle to avoid sliding inwards  $e \leq f_{\max}$

18. Which one of the following is NOT present in the acid rain?
- (A)  $\text{HNO}_3$  (C)  $\text{H}_2\text{CO}_3$   
(B)  $\text{H}_2\text{SO}_4$  (D)  $\text{CH}_3\text{COOH}$

**[Ans. D]**

Acid rains are mainly caused by  $\text{HNO}_3$ ,  $\text{H}_2\text{SO}_4$ ,  $\text{H}_2\text{CO}_3$  but not by  $\text{CH}_3\text{COOH}$  as it is a weak acid.

19. The accuracy of an Electronic Distance Measuring Instrument (EDMI) is specified as  $\pm (a \text{ mm} + b \text{ ppm})$ . Which one of the following statements is correct?
- (A) Both  $a$  and  $b$  remain constant, irrespective of the distance being measured  
(B)  $a$  remains constant and  $b$  varies in proportion to the distance being measured.  
(C)  $a$  varies in proportion to the distance being measured and  $b$  remains constant.  
(D) Both  $a$  and  $b$  vary in proportion to the distance being measured.

**[Ans. B]**

In order to increase the accuracy of geodetic measurements, the effect of instrument errors is reduced by a suitable procedure of the measurements and measurement configuration or calculation corrections can be applied on the measured values. Constant corrections or corrections depending on measured distance can be used to correct distance measurement by the EDM's of the total stations base lines are used to determine the distance meters errors. The standard deviation of the measured distance.

$$\sigma = A + B \cdot D$$

Where  $A$  is 'mm' includes phase solution of EDM maximum amplitude of short periodic error or phase distance meters, maximum effect of non-linear distance errors and accuracy or an additive constant. (ppm)

' $B$ ' in 'PPM' includes the range of the typical frequency drift of the main oscillator within the specified temperature range and the maximum error which may be caused by the limited step interval of the 'ppm dial'.

$D$  = Distance measured by EDM

20. Consider the following partial differential equation

$$3 \frac{\partial^2 \phi}{\partial x^2} + B \frac{\partial^2 \phi}{\partial x \partial y} + 3 \frac{\partial^2 \phi}{\partial y^2} + 4\phi = 0$$

For this equation to be classified as parabolic, the value of  $B^2$  must be \_\_\_\_\_

**[Ans. \*] Range: 35.9 to 36.1**

$$3 \frac{\partial^2 \phi}{\partial x^2} + B \frac{\partial^2 \phi}{\partial x \partial y} + 3 \frac{\partial^2 \phi}{\partial y^2} + 4\phi = 0$$

Here  $A = 3, C = 3$

The above PDE is said to be parabolic

$$\text{If } B^2 - 4AC = 0$$

$$B^2 - 36 = 0$$

$$B^2 = 36$$

21. The matrix P is the inverse of a matrix Q. If I denotes the identity matrix, which one of the following options is correct?

(A)  $PQ = I$  but  $QP \neq I$

(C)  $PQ = I$  and  $QP = I$

(B)  $QP = I$  but  $PQ \neq I$

(D)  $PQ - QP = I$

**[Ans. C]**

$$Q^{-1} = P \dots \textcircled{1}$$

Pre-multiplying both sides of  $\textcircled{1}$  by Q

$$QQ^{-1} = QP$$

$$I = QP$$

Post multiplying both sides of  $\textcircled{1}$  by Q

$$Q^{-1}Q = PQ$$

$$I = PQ$$

$\therefore$  Option (C) is correct.

22. Vehicles arriving at an intersection from one of the approach roads follows the Poisson distribution. The mean rate of arrival is 900 vehicles per hour. If a gap is defined as the time difference between two successive vehicle arrivals (with vehicles assumed to be points), the probability (up to four decimal places) that the gap is greater than 8 seconds is \_\_\_\_\_

**[Ans. \*] Range: 0.1276 to 0.1372**

Time,  $T = 8$  sec

Mean rate of arrival,

$$q = 900 \text{ veh/hr}$$

$$= \frac{900}{60 \times 60} = 0.25 \text{ veh/sec}$$

Probability that the gap is greater than 8 sec

$$\begin{aligned} P(t \geq T = 8 \text{ sec}) &= e^{-qt} \\ &= e^{-(0.25 \times 8)} \\ &= 0.1353 \end{aligned}$$

23. Let x be a continuous variable defined over the interval  $(-\infty, \infty)$ , and  $f(x) = e^{-x-e^{-x}}$

The integral  $g(x) = \int f(x)dx$  is equal to

(A)  $e^{-x}$

(C)  $e^{-e^x}$

(B)  $e^{-e^{-x}}$

(D)  $e^{-x}$

**[Ans. B]**

$$f(x) = e^{-x-e^{-x}}$$

$$g(x) = \int f(x)dx$$

$$= \int e^{-x-e^{-x}} dx \quad \text{Put } e^{-x} = t$$

$$\begin{aligned}
 &= \int e^{-x-e^{-x}} dx \quad -e^{-x} dx = dt \\
 &\int e^{-t}(-dt) \quad e^{-x} dx = -dt \\
 &= e^{-t} \\
 &= e^{-e^{-x}}
 \end{aligned}$$

24. The number of spectral bands in the Enhanced Thematic Mapper sensor on the remote sensing satellite Landsat-7 is
- (A) 64 (C) 8  
(B) 10 (D) 15

[Ans. C]

The Landsat enhanced thematic mapper plus (ETM+) sensor is carried on Landsat-7 and images consist of 8 spectral bands with a spatial resolution of 30 m for bands 1 to 7. The resolution for band 8 (Panchromatic) is 15 m.

25. A 3 m thick clay layer is subjected to an initial uniform pore pressure of 145 kPa as shown in the figure.

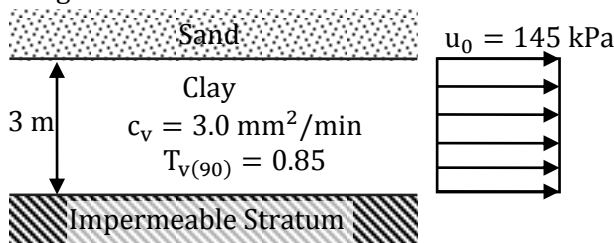

For the given ground conditions, the time (in days, rounded to the nearest integer) required for 90% consolidation would be \_\_\_\_\_

[Ans. \*] Range: 1765 to 1775

For the given clay, drainage path,  $d = H$  (single drainage)  
 $= 3 \text{ m} = 3000 \text{ mm}$

$$c_v = 3 \text{ mm}^2/\text{min}$$

$$T_{v(90)} = 0.85$$

$$T_v = \frac{c_v \cdot t}{d^2}$$

$$0.85 = \frac{3 \times t}{(3000)^2}$$

$$\therefore t = 2.55 \times 10^6 \text{ min} = 1770.83 \text{ days}$$

Say 1771 days

26. A planar truss tower structure is shown in the figure

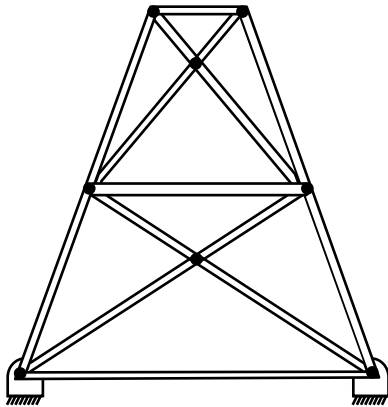

Consider the following statements about the external and internal determinacies of the truss.

- P. Externally Determine
- Q. External static Indeterminacy = 1
- R. External Static Indeterminacy = 2
- S. Internally Determinate
- T. Internal Static Indeterminacy = 1
- U. Internal Static Indeterminacy = 2

Which one of the following options is correct?

- (A) P-False; Q- True; R-False; S-False; T-False; U-True
- (B) P-False; Q- True; R-False; S-False; T-True; U-False
- (C) P-False; Q- False; R-True; S-False; T-False; U-True
- (D) P-True; Q- True; R-False; S-True; T-False; U-True

**[Ans. A]**

Number of support reactions,  $r = 4$

Number of joints,  $j = 6$

Number of members;  $m = 11$

$$D_{se} = (r - 3) = 1;$$

$$D_{si} = m - (2j - 3)$$

$$= 11 - (2 \times 6 - 3)$$

$$= 11 - 9 = 2$$

27. Consider the stepped bar made with a linear elastic material and subjected to an axial load of 1 kN, as shown in the figure

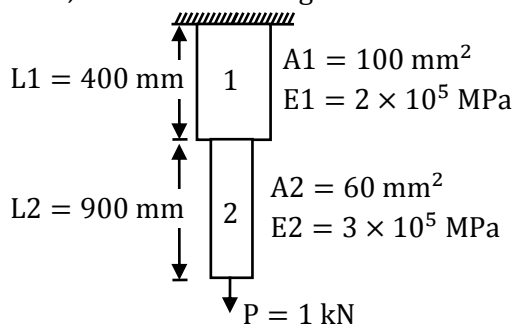



Segments 1 and 2 have cross-sectional area of  $100 \text{ mm}^2$  and  $600 \text{ mm}^2$ , Young's modulus of  $2 \times 10^5 \text{ MPa}$  and  $3 \times 10^5 \text{ MPa}$ , and length of  $400 \text{ mm}$  and  $900 \text{ mm}$ , respectively. The strain energy (in N-mm, up to one decimal place) in the bar due to the axial load is \_\_\_\_\_

[Ans. \*] Range: 34.9 to 35.1

$$U = U_1 + U_2 = \frac{P_1^2 l_1}{2A_1 E_1} + \frac{P_2^2 l_2}{2A_2 E_2}$$

$$= \frac{(1000)^2(400)}{(2)(100)(2 \times 10^5)} + \frac{(1000)^2(900)}{2(60)(3 \times 10^5)}$$

$$= 10 + 25 = 35 \text{ N-mm}$$

28. Consider the beam ABCD shown in figure

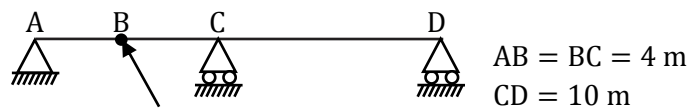

Internal hinge

For a moving concentrated load of  $50 \text{ kN}$  on the beam, the magnitude of the maximum bending moment (in kN-m) obtained at the support C will be equal to \_\_\_\_\_

[Ans. \*] Range: 199 to 201

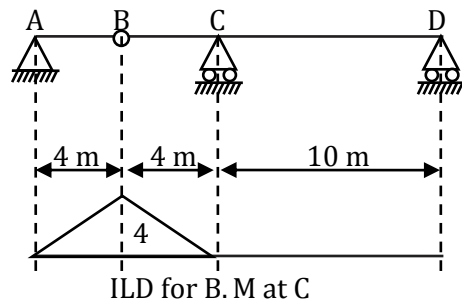

So, place the load at B for obtaining move BM at C

$$(MC)_{\text{Maximum}} = 50 \times 4 = 200 \text{ kN-m}$$

29. A column is subjected to a load through a bracket as shown in figure

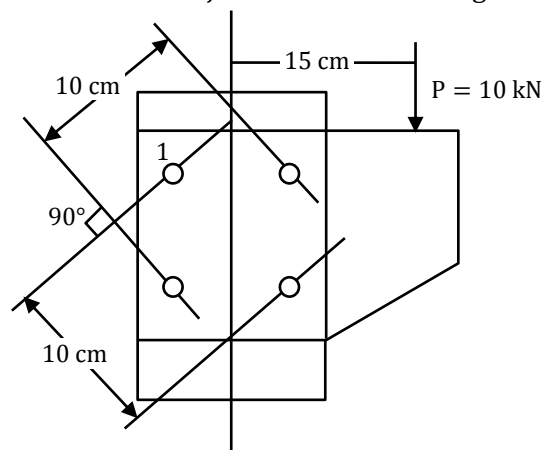

The resultant force (in kN, up to one decimal place) in the bolt 1 is \_\_\_\_\_

[Ans. \*] Range: 5.9 to 6.1

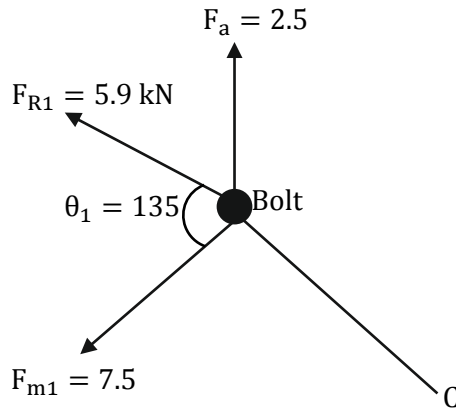

An eccentric load P may be replaced by set of one direct concentric load (P) and twisting moment (M)

$$P = 10 \text{ kN};$$

$$M = P \times e. = 10 \times 15 = 150 \text{ kN-cm}$$

$$\text{Radial distance } r_1 = r_2 = r_3 = r_4 = \frac{10}{2} = 5 \text{ cm}$$

Force in each bolt due to direct concentric load ( $F_a$ )

$$F_a = \frac{P}{n} = \frac{10}{4} = 2.5 \text{ kN}$$

Force in bolt No.1 due to twisting moment ( $F_m$ )

$$F_m = \frac{Mr_1}{\sum r^2} = \frac{150 \times 5}{4 \times 5^2} = 7.5 \text{ kN}$$

The resultant force in the bolt 1

$$F_{R1} = \sqrt{F_a^2 + F_{m1}^2 + 2F_a F_{m1} \cos \theta_1}$$

$$= \sqrt{2.5^2 + 7.5^2 + 2 \times 2.5 \times 7.5 \times \cos 135^\circ} = 5.99 \text{ kN}$$

The resultant force ( $F_{R1}$ ) in the bolt 1 (in kN) = 5.99 kN = 5.9

30. The activity details of a project are given below

Activity	Depends on	Duration (in days)
P	-	6
Q	P	15
R	Q, T	12
S	R	16
T	P	10
U	Q, T	14
V	U	16

The estimated minimum time (in days) for the completion of the project will be \_\_\_\_\_

[Ans. \*] Range: 51 to 51

**Path**

**Duration**

P-Q-U-V  $6 + 15 + 14 + 16 = 51$

P-T-Dummy-U-V  $6 + 10 + 0 + 14 + 16 = 46$

P-T-Dummy-R-S  $6 + 10 + 0 + 12 + 16 = 44$

Minimum time for the completion of the project = 51 days

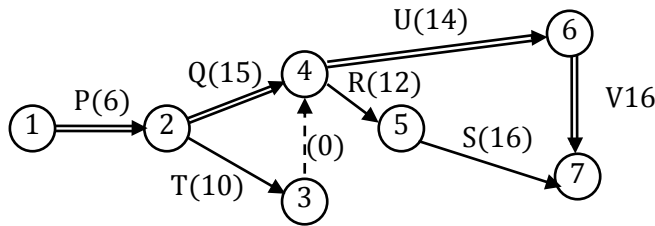

31. The value of M in the beam ABC shown in the figure is such that the joint B does not rotate.

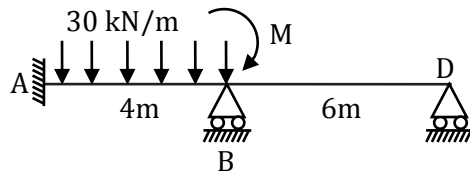

The value of support reaction (in kN) at B should be equal to \_\_\_\_\_

[Ans. \*] Range: 59.0 to 61.0

If joint B is not allowed to rotate the AB portion behaves like a fixed beam

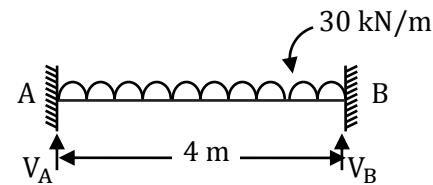

$$V_A = V_B = \frac{Wl}{2} = \frac{30 \times 4}{2} = 60 \text{ kN}$$

32. Two wastewater streams A and B, having an identical ultimate BOD are getting mixed to form the stream C. The temperature of the stream A is 20°C and the temperature of the stream C is 10°C. It is given that.

- i. The 5-day BOD of the stream A measured at 20°C = 50 mg/l
- ii. BOD rate constant (base 10) at 20°C = 0.115 per day
- iii. Temperature coefficient = 1.135

The 5-day BOD (in mg/l, up to one decimal place) of the stream C, calculated at 10°C is \_\_\_\_\_

[Ans. \*] Range: 20.0 to 22.0

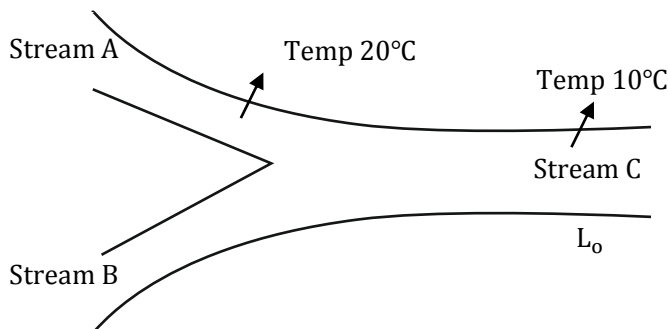

Ultimate BOD of stream A = ultimate BOD of stream B

∴ Ultimate BOD of stream 'C' = ultimate BOD of stream A =  $L_o$

5 day BOD @ 20°C for stream A  $y_5^{20^\circ\text{C}} = 50 \text{ mg/l}$

∴  $y_5^{20^\circ\text{C}} = L_o [1 - 10^{-k_{20} \times 5}]$

$50 = L_o [1 - 10^{-0.115 \times 5}]$

$$L_o = 68.126 \text{ mg/l}$$

$$k_T = k_{20}(1.135)^{T-20}$$

$$k_{10} = 0.115(1.135)^{10-20} = 0.0324 \text{ d}^{-1}$$

5 day BOD of stream @ 10°C

$$y_5^{10^\circ\text{C}} = L_o[1 - 10^{-k_{10} \times 5}]$$

$$= 68.126[1 - 10^{-0.0324 \times 5}]$$

$$= 21.2 \text{ mg/l}$$

33. A particle of mass 2 kg is travelling at a velocity of 1.5 m/s. A force  $f(t) = 3t^2$  (in N) is applied to it in the direction of motion for a duration of 2 seconds, where  $t$  denotes time in seconds. The velocity (in m/s, up to one decimal place) of the particle immediately after the removal of the force is \_\_\_\_\_

[Ans. \*] Range: 5.4 to 5.6

$m = 2 \text{ kg}$ ; velocity = 1.5 m/s = Initial

$$f(t) = 3t^2$$

$$f(t) = m \frac{dv}{dt} \Rightarrow f(t)dt = mdv$$

$$\int_0^2 3t^2 dt = m \int_{1.5}^v dv$$

$$\left[ \frac{3t^3}{3} \right]_0^2 = m[V]_{1.5}^v \Rightarrow 2^3 = 2 \times [V - 1.5]$$

$$\Rightarrow 8 = 2V - 3$$

$$V = \frac{8 + 3}{2} = 5.5 \text{ m/s}$$

34. The queue length (in number of vehicles) versus time (in seconds) plot for an approach to a signalized intersection with the cycle length of 96 seconds is shown in the figure (not drawn to scale)

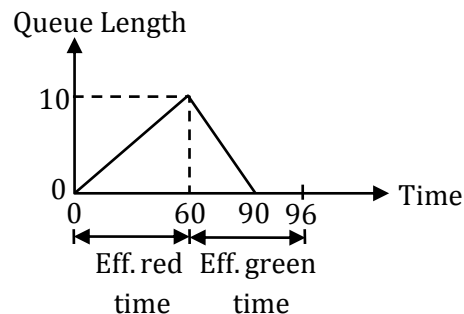

At time  $t = 0$ , the light has just turned red. The effective green time is 36 seconds, during which vehicles discharge at the saturation flow rate,  $s$  (in vph). Vehicles arrive at a uniform rate,  $v$  (in vph), throughout the cycle. Which one of the following statements is TRUE?

- (A)  $v = 600$  vph, and for this cycle, the average stopped delay per vehicle = 30 seconds  
 (B)  $s = 1800$  vph, and for this cycle, the average stopped delay per vehicle = 28.125 seconds  
 (C)  $v = 600$  vph, and for this cycle, the average stopped delay per vehicle = 45 seconds  
 (D)  $s = 1200$  vph, and for this cycle, the average stopped delay per vehicle = 28.125 seconds

[Ans. B]

35. For the function  $f(x) = a + bx, 0 \leq x \leq 1$ , to be a valid probability density function, which one of the following statements is correct?

(A)  $a = 1, b = 4$

(C)  $a = 0, b = 1$

(B)  $a = 0.5, b = 1$

(D)  $a = 1, b = -1$

[Ans. B]

$$f(x) = a + bx, 0 \leq x \leq 1$$

$$\int_{-\infty}^{\infty} f(x) dx = 1 \quad (\because \text{Total probability} = 1)$$

$$\int_{-\infty}^{\infty} (a + bx) dx = 1$$

$$\Rightarrow \left( ax + \frac{bx^2}{2} \right)_0^1 = 1$$

$$\Rightarrow a + \frac{b}{2} = 1$$

$$\Rightarrow 2a + b = 2 \dots \dots \textcircled{1}$$

Only option B,  $a = 0.5, b = 1$ , satisfying equation  $\textcircled{2}$

36. The infinite sand slope shown in the figure is on the verge of sliding failure. The ground water table coincides with the ground surface. Unit weight of water  $\gamma_w = 9.81 \text{ kN/m}^3$ .

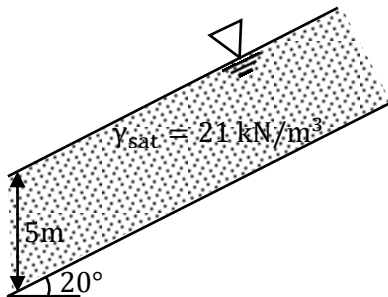

The value of the effective angle of internal friction (in degrees, up to one decimal place) of the sand is \_\_\_\_\_

[Ans. \*] Range: 34.0 to 34.5

For an infinite slope with seepage parallel to slope the F.O safety against sliding,

$$F = \frac{\gamma' \tan \phi'}{\gamma_{\text{sat}} \tan i} \quad (\text{For pure sands})$$

If  $F = 1$ , the slope will be at verge of failure

$$\therefore 1 = \frac{\gamma' \tan \phi'}{\gamma_{\text{sat}} \tan i}$$

$$1 = \frac{\gamma_{\text{sat}} \cdot \gamma_w \tan \phi'}{\gamma_{\text{sat}} \tan i}$$

$$1 = \frac{21 - 9.81 \tan \phi'}{21 \tan 20^\circ}$$

$$\therefore \phi = 34.34^\circ$$

$$\text{Say} = 34.3'$$

37. A sluice gate used to control the flow in a horizontal channel of unit-width is shown in figure

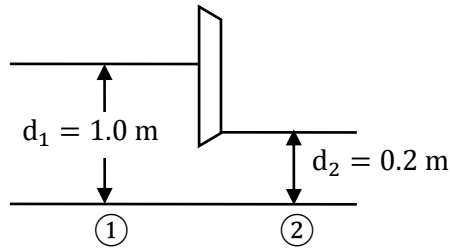

It is observed that the depth of flow is 1.0 m upstream of the gate, while the depth is 0.2 mm downstream of the gate. Assuming a smooth flow transition across the sluice gate, i.e., without any energy loss, and the acceleration due to gravity as  $10 \text{ m/s}^2$ , the discharge (in  $\text{m}^3/\text{s}$ , up to two decimal places) passing under the sluice gate is \_\_\_\_\_

[Ans. \*] Range: 0.80 to 0.83

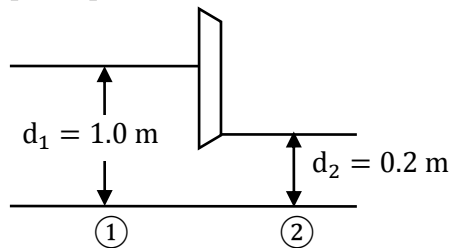

Since it is horizontal surface the specific energy is same at both upstream and downstream sections. Equating specific energy's

$$E_1 = E_2$$

$$y_1 + \frac{V_1^2}{2g} = y_2 + \frac{V_2^2}{2g}$$

Let  $y_1, y_2$  and  $V_1, V_2$  are the depths and velocities of upstream and downstream sections respectively.

$q$  = discharge per meter width

$$q = y_1 V_1 \Rightarrow V_1 = \frac{q}{y_1}$$

$$q = y_2 V_2 \Rightarrow V_2 = \frac{q}{y_2}$$

$$\therefore y_1 + \frac{q^2}{2gy_1^2} = y_2 + \frac{q^2}{2gy_2^2}$$

$$1 + \frac{q^2}{2 \times 10 \times 1^2} = 0.2 + \frac{q^2}{2 \times 10(0.2)^2}$$

$$1 + 0.05 q^2 = 0.2 + 1.25q^2$$

$$0.8 = 1.2q^2$$

$$q = 0.816 \text{ m}^3/\text{sec}/\text{m}$$

$$\therefore \text{Discharge } Q = 0.816 \text{ m}^3/\text{sec} \approx 0.82$$

38. Group –I contains three broad classes of irrigation supply canal outlets. Group II presents hydraulic performance attributes.

Group I	Group II
P. Non-modular outlet	1. Outlet discharge depends on the water levels in both the supply canal as well as the receiving water course.
Q. Semi-modular outlet	2. Outlet discharge is fixed and is independent of the water levels in both the supply canal as well as the receiving water course
R. Modular outlet	3. Outlet discharge depends only on the water level in the supply canal

The correct match of the items in Group I with the items in Group II is

- (A) P – 1 ; Q – 2; R – 3  
(B) P – 3; Q – 1; R – 2  
(C) P – 2; Q – 3; R – 1  
(D) P – 1; Q – 3; R – 2

[Ans. D]

$$\begin{aligned} \text{Modular outlet } Q_{\text{module}} &= f[\Delta Q_{\text{Parent}}] \\ &= f[Q_{\text{Daughter}}] \end{aligned}$$

Semi-Modular

$$\begin{aligned} Q_{\text{module}} &= f[\Delta Q_{\text{Parent}}] \\ &= f[Q_{\text{Daughter}}] \end{aligned}$$

Non- Modular

$$\begin{aligned} Q_{\text{Module}} &= f[\Delta Q_{\text{Parent}}] \\ &= f[\Delta Q_{\text{Daughter}}] \end{aligned}$$

39. Consider the matrix  $\begin{bmatrix} 5 & -1 \\ 4 & 1 \end{bmatrix}$ . Which one of the following statements is TRUE for the eigenvalues and eigenvectors of this matrix?
- (A) Eigenvalue 3 has a multiplicity of 2, and only one independent eigenvector exists.  
(B) Eigenvalue 3 has a multiplicity of 2, and two independent eigen vectors exist.  
(C) Eigenvalue 3 has a multiplicity of 2, and no independent eigen vector exists  
(D) Eigenvalues are 3 and –3, and two independent eigenvectors exist

[Ans. A]

$$\text{Let } A = \begin{bmatrix} 5 & -1 \\ 4 & 1 \end{bmatrix}$$

$$\lambda^2 - \lambda(6) + (5 + 4) = 0$$

$$\lambda - 6\lambda + 9 = 0$$

$$(\lambda - 3)^2 = 0$$

$\therefore \lambda = 3, 3$  are eigen values of A

Algebraic multiplicity of eigen value 3 is 2

$$\text{For } \lambda = 3, A - \lambda I = A - 3I = \begin{bmatrix} 2 & -1 \\ 4 & -2 \end{bmatrix}$$

$$R_2 \rightarrow R_2 - 2R_1$$

$$A - 3I = \begin{bmatrix} 2 & -1 \\ 0 & 0 \end{bmatrix}$$

$$\text{Rank of } (A - 3I) = 1$$

$$\begin{aligned} \therefore \text{Number of LI eigen vectors} &= n - r \\ &= 2 - 1 = 1 \end{aligned}$$

40. The laboratory tests on a soil sample yields the following results; natural moisture content = 18% liquid limit = 60%, plastic limit = 25%, percentage of clay sized fraction = 25%. The liquidity index and activity (as per the expression proposed by Skempton) of the soil, respectively, are
- (A) -0.2 and 1.4 (C) -1.2 and 0.714  
(B) 0.2 and 1.4 (D) 1.2 and 0.714

**[Ans. A]**

Given

$$w = 18\%, w_L = 60\%, w_P = 25\%, C = 25\%$$

$$\text{Liquidity index, } I_L = \frac{w - w_P}{w_L - w_P} = \frac{18 - 25}{60 - 25} = -0.2$$

$$I_P = w_L - w_P = 60 - 25 = 35$$

$$\text{Activity, } A = \frac{I_P}{C} = \frac{35}{25} = 1.4$$

41. The solution of the equation  $\frac{dQ}{dt} + Q = 1$  with  $Q = 0$  at  $t = 0$  is
- (A)  $Q(t) = e^{-t} - 1$  (C)  $Q(t) = 1 - e^t$   
(B)  $Q(t) = 1 + e^{-t}$  (D)  $Q(t) = 1 - e^{-t}$

**[Ans. D]**

$$\frac{dQ}{dt} + Q = 1 \text{ with } Q = 0 \text{ at } t = 0$$

$$\Rightarrow \frac{dQ}{dt} = 1 - Q$$

$$\Rightarrow \frac{dQ}{1 - Q} = dt$$

$$\Rightarrow \int \frac{dQ}{1 - Q} = \int dt$$

$$\Rightarrow \ln(Q - 1) = -t + \ln c$$

$$\Rightarrow (Q - 1) = e^{-t} + C$$

$$\Rightarrow Q = 1 + e^{-t} \cdot e^C \dots \textcircled{1}$$

Applying initial condition we get

$$0 = 1 + e^C$$

$$e^C = -1$$

substituting in (1), we get

$$Q = 1 - e^{-t}$$



42. Water flows through a 90° bend in a horizontal plane as depicted in the figure

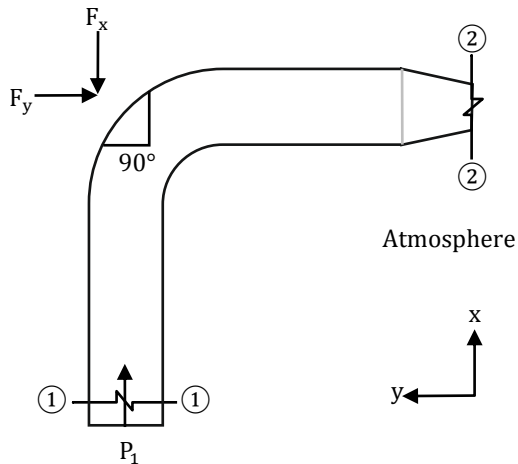

A pressure of 140 kPa is measured at section 1-1. The inlet diameter marked at section 1 – 1 is  $27/\sqrt{\pi}$  cm. While the nozzle diameter marked at section 2 – 2 is  $14/\sqrt{\pi}$  cm. Assume the following.

- (i) Acceleration due to gravity =  $10 \text{ m/s}^2$ .
- (ii) Weights of both the bent pipe segment as well as water are negligible.
- (iii) Friction across the bend is negligible

The magnitude of the force (in kN, up to two decimal places) that would be required to hold the pipe section is \_\_\_\_\_

[Ans. \*]Range: 2.50 to 3.75

From the question

$$A_1 = 0.018225 \text{ m}^2$$

$$A_2 = 4.9 \times 10^{-3} \text{ m}^2$$

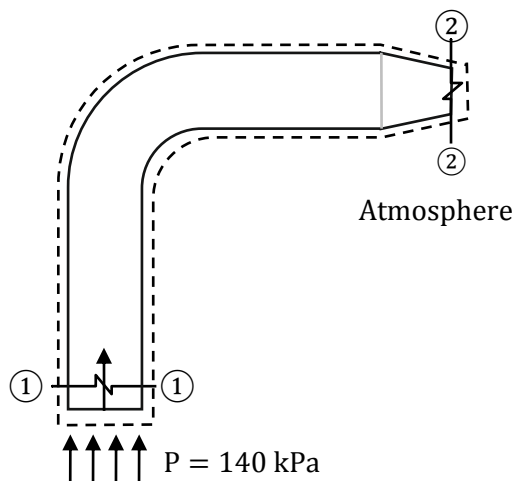

From continuity equation

$$A_1 V_1 = A_2 V_2$$

$$V_1 = V$$

$$\Rightarrow V_2 = \left(\frac{27}{14}\right)^2 \times V$$

From momentum equation

$$\vec{F} = \frac{\partial}{\partial t} \iiint_{cv} \rho \vec{V} \cdot dV + \int_{cs} \vec{V} \cdot \rho \vec{V} \cdot \vec{dA}$$

From Bernoulli's equation:

$$\frac{P_1}{\rho g} + \frac{V_1^2}{2g} = \frac{P_2}{\rho g} + \frac{V_2^2}{2g}$$

Substitute  $P_1 = 140 \times 10^3$

$$\rho = 1000 \text{ kg/m}^3$$

$$g = 9.81$$

$$V_1 = V$$

$$V_2 = \left(\frac{27}{14}\right)^2 \times V$$

$$\Rightarrow V_1 = V = 4.67 \text{ m/s}$$

$$V_2 = 17.39 \text{ m/s}$$

Force in X direction:

$$F_X = (V_2)^2 \times \rho \times A_2$$

$$F_X = 1163.81 \text{ N}$$

Force in Y direction:

$$F_Y + (P \times A_1) = -(V_1)^2 \times \rho \times A_1$$

$$F_Y = -2948.96 \text{ N}$$

$$F_{\text{net}} = \sqrt{F_X^2 + F_Y^2} = 3.17 \text{ kN}$$

43. A pre-tensioned rectangular concrete beam 150 mm wide and 300 mm depth is pre-stressed with three straight tendons, each having a cross-sectional area of  $50 \text{ mm}^2$ , to an initial stress of  $1200 \text{ N/mm}^2$ . The tendons are located at 100 mm from the soffit of the beam. If the modular ratio is 6, the loss of pre-stressing force (in kN, up to one decimal place) due to the elastic deformation of concrete only is \_\_\_\_\_

[Ans. \*]Range: 4.5 to 5.0

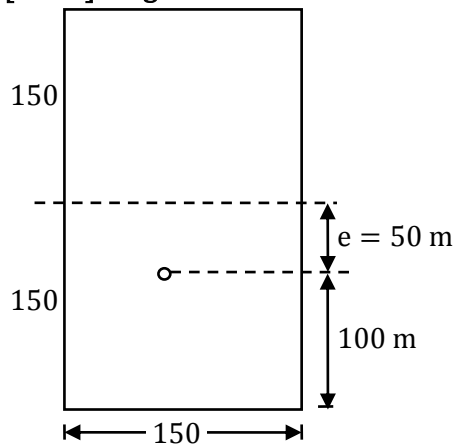

$$b = 150 \text{ mm}$$

$$D = 300 \text{ mm}$$

$$A_s = 3 - 50 \text{ mm}^2$$

$$\sigma = 1200 \text{ N/mm}^2$$

$$m = 6$$

$\Delta P = ?$  Loss of prestressing force

Loss of prestress due to elastic deformation in pretensioning

$$\Delta\sigma = m f_c$$

$$f_c = \frac{P}{A} + \frac{Pe}{I} \cdot e$$

$$P = \sigma_o A_s = 1200 \times 50 \times 3 = 180 \text{ kN}$$

$$f_c = \frac{P}{A} + \frac{Pe}{I} \cdot e$$

$$= \frac{180 \times 10^3}{150 \times 300} + \frac{180 \times 10^3 \times 50}{\frac{150 \times 300^3}{12}} \times 50$$

$$= 4 + 1.3 = 5.3 \text{ N/mm}^2$$

$$\Delta\sigma = 6 \times 5.3 = 31.8 \text{ N/mm}^2$$

$$\Delta P = 4.8 \text{ kN}$$

44. The spherical grit particles, having a radius of 0.01 mm and specific gravity of 3.0 need to be separated in a settling chamber. It is given that

- $g = 9.81 \text{ m/s}^2$
- The density of the liquid in the settling chamber =  $1000 \text{ kg/m}^3$
- The kinematic viscosity of the liquid in the settling chamber =  $10^{-6} \text{ m}^2/\text{s}$

Assuming laminar conditions, the settling velocity (in mm/s, up to one decimal place) is \_\_\_\_\_

[Ans. \*]Range: 0.3 to 0.5

$$d = 0.01 \text{ mm} = 0.01 \times 10^{-3} \text{ m}$$

$$S = 3$$

$$g = 9.81 \text{ m/s}^2$$

$$\rho_w = 1000 \text{ kg/m}^3$$

$$V = 10^{-6} \frac{\text{m}^2}{\text{sec}}$$

$$V_s = \frac{g[S - 1]d^2}{18V} = \frac{9.81[3 - 1](0.02 \times 10^{-3})^2}{18 \times 10^{-6}}$$

$$= 4.36 \times 10^{-4} \text{ m/sec}$$

$$= 0.436 \text{ mm/sec}$$

45. The equivalent sound power level (in dB) of the four sources with the noise levels of 60 dB, 69 dB, 70 dB and 79 dB is \_\_\_\_\_

[Ans. \*]Range: 79 to 81

$$L_{\text{equ}} = 10 \log_{10} \sum \left[ 10^{\frac{L_i}{10}} \times T_i \right]$$

$$10 \log_{10} \left[ 10^{\frac{60}{10}} + 10^{\frac{69}{10}} + 10^{\frac{70}{10}} + 10^{\frac{79}{10}} \right] = 79.92 \text{ dB} \approx 80 \text{ dB}$$

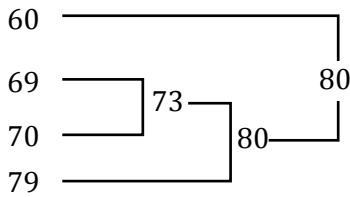

46. Consider the equation  $\frac{du}{dt} = 3t^2 + 1$  with  $u = 0$  at  $t = 0$ . This is numerically solved by using the forward Euler method with a step size  $\Delta t = 2$ . The absolute error in the solution at the end of the first time step is \_\_\_\_\_

[Ans. \*]Range: 7.95 to 8.05

$$\frac{du}{dt} = 3t^2 + 1, u(0) = 0, h = \Delta t = 2$$

$$\Rightarrow du = (3t^2 + 1)dt$$

$$\Rightarrow \int du = \int (3t^2 + 1)dt$$

$$u = t^3 + t + c \dots \textcircled{1}$$

$$u(0) = 0 : \textcircled{1} \Rightarrow 0 = C$$

$$\textcircled{1} \Rightarrow u = t^3 + t$$

Now, at  $t = 2, u = 2^3 + 2 = 10$  is the exact solution

The first approximation is

$$u_1 = u_0 + hf(t_0, u_0), \text{ where } f(t, u) = 3t^2 + 1$$

$$= 0 + 2f(0, 0)$$

$$= 2(1)$$

$u_1 = 2$  is the numeral solution

(or) approximate solution

$$\text{Error} = |\text{Exact solution} - \text{Approximate solution}|$$

$$= |10 - 2| = 8$$

47. It is proposed to drive H-piles up to a depth of 7 m at a construction site. The average surface area of the H-pile is  $3 \text{ m}^2$  per meter length. The soil at the site is homogenous sand, having an effective friction angle of  $32^\circ$ . The ground water table (GWT) is at a depth of 2 m below the ground surface. The unit weights of the soil above and below the GWT are  $16 \text{ kN/m}^3$  and  $19 \text{ kN/m}^3$ , respectively. Assume the earth pressure coefficient,  $K = 1.0$ , and the angle of wall friction,  $\delta = 23^\circ$ . The total axial frictional resistance (in kN, up to one decimal place) mobilized on the pile against the driving is \_\_\_\_\_

[Ans. \*]Range: 385.0 to 390.0

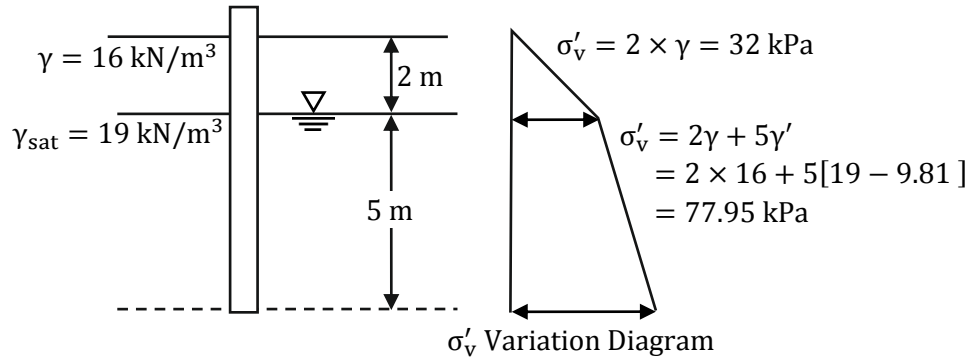

Dividing the pile length into two convenient parts of 2 m length and 5 m length as shown, the total ultimate frictional resistance is:

$$\begin{aligned}
 Q_s &= A_s \cdot K \cdot \sigma'_{v_a} \cdot \tan \delta \\
 &= (3 \times 2) \times 1 \times \left( \frac{0 + 32}{2} \right) \tan 23^\circ + (3 \times 5) \times 1 \times \left( \frac{32 + 77.95}{2} \right) \tan 23^\circ \\
 &= 40.75 + 350.03 \\
 &= 390.78 \text{ say } 390.8 \text{ kN}
 \end{aligned}$$

48. The wastewater having an organic concentration of 54 mg/l is flowing at a steady rate of  $0.8 \text{ m}^3/\text{day}$  through a detention tank of dimensions  $2 \text{ m} \times 4 \text{ m} \times 2 \text{ m}$ . If the contents of the tank are well mixed and the decay constant is 0.1 Per day, the outlet concentration (in mg/l, up to one decimal place) is \_\_\_\_\_

[Ans. \*] Range: 17. 9 to 18.1

49. The radius of a horizontal circular curve on a highway is 120 m. The design speed is 60 km/hour, and the design coefficient of lateral friction between the tyre and the road surface is 0.15. The estimated value of superelevation required (if full lateral friction is assumed to develop), and the value of coefficient of friction needed (if no superelevation is provided) will, respectively, be

- (A)  $\frac{1}{11.6}$  and 0.10 (C)  $\frac{1}{11.6}$  and 0.24  
 (B)  $\frac{1}{10.5}$  and 0.37 (D)  $\frac{1}{12.9}$  and 0.24

[Ans. C]

Design speed,  $R = 120 \text{ m}$

Design speed,  $V = 60 \text{ km/hr (16.67 m/s)}$

Coefficient of lateral friction,  $f = 0.15$

- (i) Superelevation for the development of full friction

$$e + f = \frac{V^2}{gR} \rightarrow e + 0.15 = \frac{16.67^2}{9.87 \times 120}$$

$$e = 0.086 = \frac{1}{11.63} \approx \frac{1}{11.6}$$

- (ii) For no superelevation coefficient of friction required is

$$e + f = \frac{V^2}{gR}$$

$$0 + f = \frac{16.67^2}{9.81 \times 120}$$

$$f = 0.236 = 0.24$$

50. Consider two axially loaded columns, namely, 1 and 2, made of a linear elastic material with Young's modulus  $2 \times 10^5$  MPa, square cross-section with side 10 mm, and length 1 m. For Column 1, one end is fixed and the other end is free. For column 2, one end is fixed and the other end is pinned. Based on the Euler's theory, the ratio (up to one decimal place) of the buckling load of Column 2 to the buckling load of column 1 is \_\_\_\_\_

[Ans. \*] Range: 7.9 to 8.3

Column 1	Column 2
Fix and free $l = 2L$	Fix hinged $l = \frac{1}{\sqrt{2}}$

$$\frac{P_2}{P_1} = \frac{l_1^2}{l_2^2} = \frac{(2L)^2}{\left(\frac{L}{\sqrt{2}}\right)^2} = 4 \times 2 = 8$$

51. The observed bearings of a traverse are given below

Line	Bearing	Line	Bearing
PQ	46°15'	QP	226°15'
QR	108°15'	RQ	286°15'
RS	201°30'	SR	20°30'
ST	321°45'	TS	141°45'

The station(s) most likely to be affected by the local attraction is /are

- (A) Only R (C) R and S  
(B) Only S (D) P and Q

[Ans. A]

Difference between FB & BB of PQ = 180°

Difference between FB & BB of TS = 180°

Hence stations P, Q, T & S are free from local attraction

But station 'R' is affected by local attraction.

52. A 1 m wide rectangular channel has a bed slope of 0.0016 and the Manning's roughness coefficient is 0.04. Uniform flow takes place in the channel at a flow depth of 0.5 m. At a particular section, gradually varied flow (GVF) is observed and the flow depth is measured as 0.6 m. The GVF profile at that section is classified as

- (A)  $S_1$  (C)  $M_1$   
(B)  $S_2$  (D)  $M_2$

[Ans. C]

$y = 0.6$  m

$y_n = 0.5$  m

$B = 1$  m

$S = 0.0016$

$n = 0.04$

$$y_c = \left(\frac{q^2}{g}\right)^{\frac{1}{3}}$$

$$q = \frac{Q}{B} = \frac{B \cdot y_n \cdot V}{B} = y_n^v$$

$$= y_n \times \frac{1}{n} \times R^{2/3} S^{1/2}$$

$$q = y_n \times \frac{1}{n} \left(\frac{y_n}{2}\right)^{2/3} S^{1/2}$$

$$= 0.5 \times \frac{1}{0.04} \left(\frac{0.5}{2}\right)^{2/3} 0.0016^{1/2}$$

$$= 0.1984 \text{ m}^2/\text{s}/\text{m}$$

$$y_c = \left(\frac{0.1984^2}{9.81}\right)^{1/3} = 0.1589 \text{ m}$$

$$\therefore y > y_n > y_c$$

The GVF profile at section of flow depth 0.6 is  $M_1$

53. A consolidated un-drained ( $\overline{CU}$ ) triaxial compression test is conducted on a normally consolidated clay at a confining pressure of 100kPa. The deviator stress at failure is 80 kPa, and the pore-water pressure measured at failure is 50 kPa. The effective angle of internal friction (in degrees, up to one decimal place) of the soil is\_\_\_\_\_

**[Ans. \*] Range: 25.5 to 27.0**

For NC clay in an CU test, both  $C_u$  &  $C' = 0$

Given  $\sigma_3 = 100$  kPa,  $\sigma_d = 80$  kPa,  $u = 50$  kPa

To find  $\phi'$

$$\sigma'_1 = \sigma'_3 \tan^2 \left(45 + \frac{\phi'}{2}\right) \quad (\because C' = 0)$$

$$(\sigma_1 - u) = (\sigma_3 - u) \tan^2 \left(45 + \frac{\phi'}{2}\right)$$

$$(100 + 80 - 50) = (100 - 50) \tan^2 \left(45 + \frac{\phi'}{2}\right)$$

$$130 = 50 \tan^2 \left(45 + \frac{\phi'}{2}\right)$$

$$\therefore \phi' = 26.39^\circ \approx 26.4^\circ$$

54. An effective rainfall of 2-hour duration produced a flood hydrograph peak of 200 m<sup>3</sup>/s. The flood hydrograph has a base flow of 20 m<sup>3</sup>/s. If the spatial average rainfall in the watershed for the duration of storm is 2 cm and the average loss rate is 0.4 cm/hour, the peak of 2-hour unit hydrograph (in m<sup>3</sup>/s-cm, up to one decimal place) is\_\_\_\_\_

**[Ans. \*] Range: 149.0 to 151.0**

Peak ord of 2 hr FHG = 200 m<sup>3</sup>/sec

Base flow = 20 m<sup>3</sup>/sec

Peak ord of 2hr DRH = [peak ord of 2hr FHG]–Base flow

$$= 200 - 20 = 180 \text{ m}^3/\text{sec}$$

$$P_e = 2 \text{ cm}$$

$$t_e = 2 \text{ hr}$$

$$\phi\text{-Index} = 0.4 \text{ cm/hr}$$

$$\phi\text{-Index} = \frac{P_e - R}{t_e}$$

$$0.4 = \frac{2 - R}{2}$$

$$R = 1.2 \text{ cm}$$

$$\begin{aligned} \text{Peak ord of 2 hr UHG} &= \frac{\text{Peak ord of 2hr DRH}}{R} \\ &= \frac{180}{1.2} = 150 \text{ m}^3/\text{sec} \end{aligned}$$

55. The following observations are made while testing aggregate for its suitability in pavement construction:

- i. Mass of oven-dry aggregate in air = 1000 g
- ii. Mass of saturated surface-dry aggregate in air = 1025 g
- iii. Mass of saturated surface-dry aggregate under water = 625 g

Based on the above observations, the correct statement is

- (A) bulk specific gravity of aggregate = 2.5 and water absorption = 2.5%
- (B) bulk specific gravity of aggregate = 2.5 and water absorption = 2.4%
- (C) apparent specific gravity of aggregate = 2.5 and water absorption = 2.5%
- (D) apparent specific gravity of aggregate = 2.5 and water absorption = 2.4%

**[Ans. A]**

Bulk specific gravity; G

$$\begin{aligned} G &= \frac{\text{Oven dryweight}}{\text{Saturated surface dry weight} - \text{Weight in water}} \\ &= \frac{1000}{1025 - 625} \\ &= 2.5 \end{aligned}$$

Water absorption; w

$$\begin{aligned} w &= \frac{\text{Saturated surface dry weight} - \text{Oven dryweight}}{\text{Oven dryweight} \times 100} \\ &= \frac{1025 - 1000}{1000} \times 100 \\ &= 2.5\% \end{aligned}$$